

EE 215 - Laboratory 1 - Introduction to Circuit Analysis

Authors

D. Wilson, R.D. Christie, W.R. Lynes, K.F. Böhringer, M. Ostendorf

Objectives

At the end of this lab, you will be able to:

- Check continuity with a multimeter
- Understand and describe breadboard internal connections
- Create circuits on a breadboard
- Measure dc voltage, current and resistance using a multimeter
- Identify basic electronic components
- Identify resistor and values
- Calculate resistance from dc voltage and current measurements
- Compute resistor power dissipation and compare to power ratings
- Design voltage divider circuits
- Optionally, describe the DC steady state operation of capacitors and inductors

Materials and Supplies

You will need to pick up an EE 215 lab parts kit from EE stores, and purchase a multimeter. Groups may choose to purchase one multimeter and move it from person to person to take measurements, although you may find that it is more convenient for each individual to get their own meter. Every individual may obtain his or her own parts kit.

Lab Parts Kit: This kit contains components for all the home lab experiments in EE 215 as well as several spares. It can be obtained at EE stores (www.ee.washington.edu/stores/) located in room EE 137.

The cost of the EE 215 lab kit is supported by part of your EE215 course fee. (For more on course fees, see www.ee.washington.edu/academic/coursefees/.)

If you lose or break parts or want to play with more complicated circuits, you can purchase a wide range of electronic components (used in EE class lab work) from the EE store. The store has limited opening hours but does have its entire stock available for purchase online.

Multimeter: You need a multimeter that can measure AC and DC voltage, DC current and resistance. Ones that measure AC current, frequency and/or capacitance can be useful in the long run, but are not required for the course. A good multimeter costs \$45-55, and you can spend more if you want to. Multimeter costs are not supported by course fees. The EE store has two models of multimeter in stock.

Economy Digital Multimeter model MAS830	\$12.00
---	---------

Digital Multimeter with RS-232 interface model MAS345	\$52.00
---	---------

Before you make the economy choice, think about this: a good multimeter will be with you for years and is a useful part of a house, apartment or automotive toolkit, as well as essential for any electronics work. Of course you are free to purchase your multimeter from other sources, these include local electronics stores listed on the EE store web page, on-line stores also listed on the EE store web page, and even Sears.

Optional Stuff: If you get a multimeter that does not have clips at the end of at least one set of leads (sometimes these are an option), you might want to invest in a pair of wires with alligator clips on either end. This can make

taking measurements much more convenient, and they're cheap. The EE store has a universal test lead kit in stock (\$4.00). The EE store also stocks a bare bones tool kit (\$10.00) that contains needle nose pliers, wire strippers, screwdriver and soldering iron. The pliers are quite useful for the EE 215 labs.

Parts for This Lab

Separate and identify the following from your parts kit:

- Breadboard
- Jumper Wire Kit
- Mystery Resistor, glass, yellow marking "MIS60G 8251F T1 1%".
- Various 1/4 W 5% resistors, marked with color code.
- 0.1 μ Farad Ceramic Disc Capacitor (optional procedure)
- 100mH Inductor (optional procedure)
- 1000 Ω potentiometer (1/4 Watt)
- Potentiometer adjustment tool
- 9 V battery and connector
- 1.5 V battery and connector

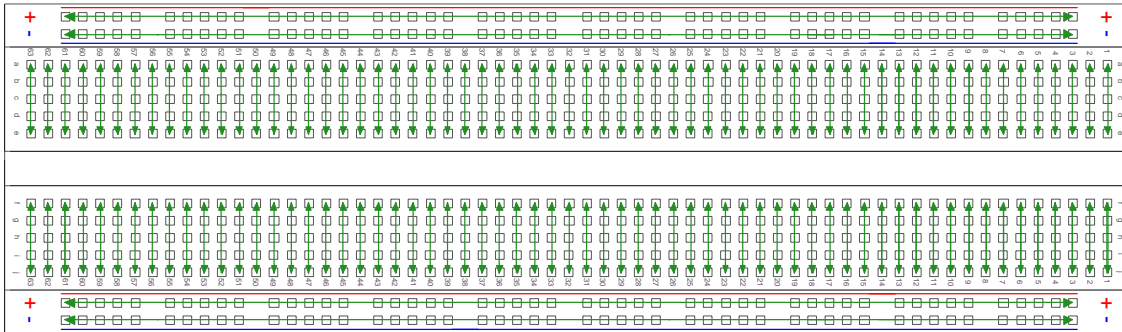

Figure 1 - Breadboard connectivity diagram

The *breadboard* (Figure 1) is typically a white piece of plastic with lots of tiny little holes in it. You stick wires and component leads into the holes to make circuits. Some of the holes are already electrically connected with each other. The holes are 0.1 inch apart, which is the standard spacing for leads on integrated circuit dual in-line packages. You will verify the breadboard internal connections in this lab.

Breadboards are sometimes supplied with an adhesive back and a separate metal backing plate. Go ahead and stick the plate onto the back of the breadboard - it will act as a ground plane and cut down on stray circuit noise. Noise is NOT a problem in EE 215 labs, but may be important when you use the breadboard in later courses.



Figure 2 - Jumper Wire Kit with breadboard

The arrowed green lines in Figure 1 show how the holes are connected internally in the breadboard. Note how all of the holes in one outer row (with polarity mark + or - and with a red or blue line) are connected together. The + rows are typically connected to the positive terminal of a battery or power supply. The - rows are typically connected to the negative terminal. Thus the rows act as power supply buses, running the length of the breadboard. The central section of the breadboard is split into two. Each half consists of 63 columns of 5 holes. The 5 holes in each of these columns are connected together. The gap between each set of 63 columns allows a Dual Inline Package (DIP) integrated circuit to be used on the breadboard without its opposing pins being connected together.

The *jumper wire kit* (Figure 2) contains assorted lengths of pre-stripped wire. (Stripping means removing the insulation from an end of a wire.) Working with pre-cut and pre-stripped wire is much easier than cutting and stripping your own wire. The wire lengths are color-coded using the same colors as the resistor color code. For example a short yellow jumper wire will connect two holes that are four holes apart. Similarly a long orange jumper wire will connect two holes that are thirty holes apart.

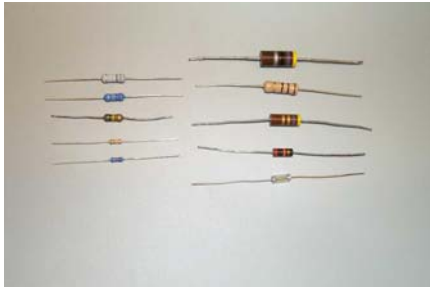

Figure 3 - Various resistors. Larger resistors have higher power ratings. The resistor circuit symbol is shown on the right.

Resistors (Figure 3) are the small, usually light brown tubular things with wires (leads) sticking out of each end and four colored rings on the body. The colored rings correspond to the resistor's value. Use the resistor color code guide supplied in the lab kit to determine a resistor value.

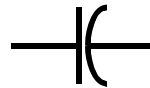

Figure 4 - Different types of capacitors. Ceramic disk capacitors are on the right in the photograph. The capacitor circuit symbol is on the right of the figure.

The ceramic disc *capacitor* is the light brown circular component with two wires. It is marked in black with the numbers "104". These numbers represent its value in pico (1×10^{-12}) Farads, pF. The third number, 4, represents the number of zeroes, so 104 is equal to $10 \times 10^4 \times 10^{-12}$ Farads or 0.1×10^{-6} Farads or 0.1 micro Farads ($0.1 \mu\text{F}$, sometimes written μF). There are several different types of capacitors, each with its own characteristic shape. Some different types are shown in Figure 4.

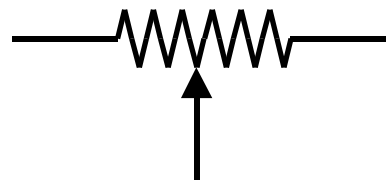
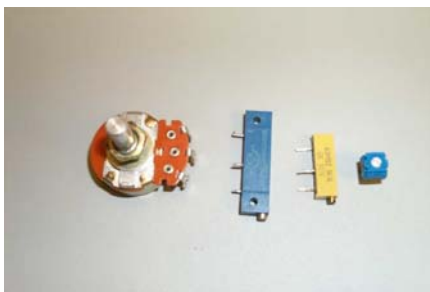

Figure 5 - Potentiometers. On the left in the picture is a typical knob-operated potentiometer, found on volume controls. In the center are two multi-turn potentiometers. On the right is a one-turn potentiometer. On the right side of the page is the potentiometer circuit symbol. It's a continuously variable voltage divider.

The $1000\ \Omega$ *potentiometer* (sometimes called a "pot") (Figure 5) is the rectangular or cubic blue device. It is a variable resistor that can be adjusted with a small screwdriver or adjustment tool (supplied in lab kit). There are two different types of pot in the lab kit. The rectangular one requires 15 – 20 turns to go from zero resistance to maximum. The cubic one requires only about $\frac{3}{4}$ of a turn.

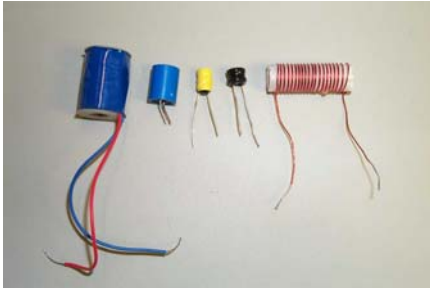

Figure 6 - Types of inductors. The LJ 410 is second from the left. On the right is the inductor circuit symbol.

The 100 mH *inductor* (Figure 6) is the blue cylindrical device with two wires. It is marked in black with LJ 410. Inside the blue plastic case is a coil of enameled copper wire. Real (non-ideal) inductors typically have a resistance of several ohms, as well as an ideal inductance.

The 9V *battery connector* is the black plastic cap with two snaps mounted on it and a couple of wires coming out of its side. The snaps fit with the snaps on the top of the 9V battery. The red wire is from the positive terminal of the battery, the black from the negative terminal. The 1.5 V battery connector is a black plastic case.

Laboratory Procedures, Measurements and Questions

Record your data and the answers to questions on a separate sheet (or sheets) of paper and hand it in at recitation section when the lab is due. You will also have to bring your breadboard with designated circuits on it to your recitation section the week the lab is due.

Procedure 1 Continuity Check (5 points)

Use your multimeter to verify the connections in your breadboard in the first 5 columns and the top two rows of the breadboard as indicated on the diagram below (Figure P1-1).



Figure P1-1 - Partial breadboard

Set your multimeter on resistance. To find out if any two holes are connected, measure the resistance between them with the multimeter. This is called a continuity check.

- a. (2 points)** Measure and record the resistance between two holes in a row of 5 connected holes. Measure and record the resistance between two holes at the opposite ends of a long side row (+ or -). Explain the difference (or lack thereof).
- b. (2 points)** Measure and record the resistance between two unconnected holes on the breadboard. What did your multimeter read? What resistance does this reading correspond to?
- c. (1 point)** Reverse the leads from the multimeter and record whether there are any differences in the multimeter reading. Do this for connected and unconnected holes.

Some hints on measuring resistance:

Never try to measure resistance in energized circuits (ones with the power on). You won't get an accurate value and you could damage your multimeter or the circuit.

Your multimeter probes probably don't fit into the breadboard holes. Stick the stripped end of a wire into each hole, and touch the other stripped ends of the wires with the multimeter probes. If you have clips at the end of your multimeter leads, or you bought those optional alligator clips, you can clip on to the ends of the wires and move the wires from hole to hole. Resistor leads also work for this purpose, but make sure you are not measuring the resistor resistance as well as the breadboard resistance!

Because the multimeter uses a low voltage to measure resistance, you can safely use your fingers to press the wires to the multimeter probes to be sure you have a good contact. If you do, though, you will put your body in parallel with the resistance you are measuring. This can be important for certain large values of resistance, those near or greater than your body resistance. It's usually not a problem for continuity checks.

Switch the multimeter to off or to the voltage setting when you are not actively measuring resistance. This minimizes battery use in the multimeter and is also a generally safer practice. (This lab is safe.)

Procedure 2 Ohm's Law (20 points)

Find the mystery resistor. This is a relatively uncommon metal film resistor without resistor color code rings, in a clear plastic package. The easy way to determine its resistance would be to measure it with your multimeter. But let's do it the hard way first.

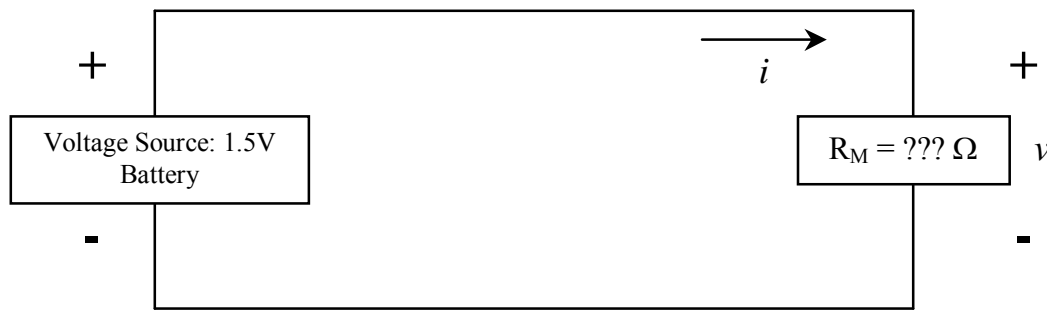

Figure P2-1 - Circuit for Procedure 2.a.

- a. (2 points) Draw the circuit schematic diagram for the circuit in Figure P2-1 using standard symbols for resistor and battery.
- b. (1 points) Construct the circuit in Figure P2-1 on your breadboard with R_M being the mystery resistor. See below for construction hints. Measure the voltage v across R_M . Record the value.
- c. (1 points) Measure the current i using your multimeter. Record the value.

Some hints on measuring current:

A multimeter set to measure current is an ammeter (amp-meter). You have to connect the ammeter into the circuit, as though it was a piece of wire, so the current you want to measure flows through it, as shown in Figure P2-2. The ammeter looks like a short circuit from the circuit's point of view. Sometimes you have to move the meter leads to different holes on the meter.

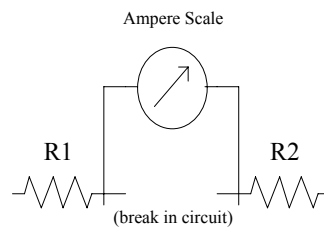

Figure P2-2 - Inserting an ammeter into a circuit for measuring current. First the connection between the circuit components $R1$ and $R2$ is broken, then the ammeter (or multimeter set to measure current) is inserted across the break. An ammeter looks like a short circuit, so the original circuit will work the same way as before the ammeter is inserted. It is wise to de-energize the circuit by disconnecting the power source before inserting the multimeter, and then re-energize to take a reading.

As soon as you are done measuring current, it is good practice to switch the multimeter back to off, or back to measuring voltage. If you inadvertently try to measure voltage with a multimeter set to current, you will short your circuit, which is not healthy for the circuit or the multimeter. The circuit may burn out components, identifiable by

charring, bad smells, cracking and general failure to work. The multimeter may blow a fuse, which can be difficult to find and replace, or just burn out. On the voltage setting, the multimeter looks like an open circuit, and probing the circuit with it is safer.

d. (2 points) Replace the 1.5 V battery with a 9 V battery and repeat steps b and c.

e. (2 points) Connect the 9V battery and the 1.5 V battery in series across the mystery resistor R_M . See Figure P2-3. Repeat steps b and c.

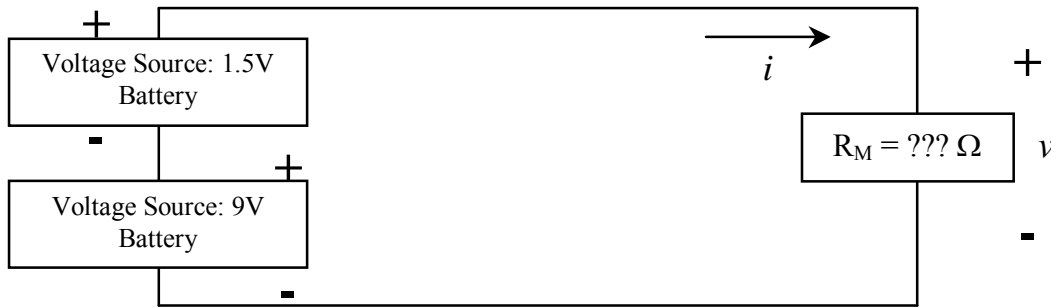

Figure P2-3 - Circuit for Procedure 2.e.

f. (4 points) Plot the three sets of voltage and current values you recorded on a graph. Do they make a straight line? Calculate the value of R_M from the slope of the straight line.

g. (4 points) Calculate the value of the mystery resistance R_M using Ohm's law for each set of data points.

h. (2 points) Take R_M out of the circuit and measure its resistance with your multimeter. Compare to markings on the resistor. Write down the measured value.

i. (2 points) Calculate the error between the average of the calculated values in step g and the measured value from step h.

Hint:

$$\text{error} = \frac{\text{calculated} - \text{measured}}{\text{calculated}} \times 100\%$$

Construction hints:

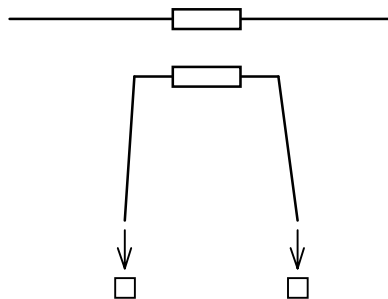

Figure P2-4 - Inserting components into breadboard holes.

Bend the resistor leads at right angles near the resistor body to make a U-shape with a flat bottom, and then insert the leads directly into breadboard holes. Make sure they go into the spring clips in the holes. Sometimes the springs

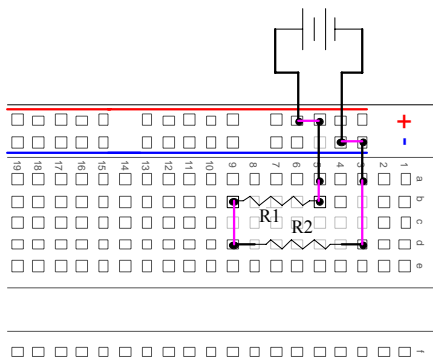

Figure P2-5 - Breadboard component layout for a voltage divider. The magenta lines represent internal breadboard connections.

don't want to let the leads in. Wiggle gently and push. With a little experience you will be able to tell when you have the leads in, and when you don't. You can do the same thing with wires.

If you really like being neat, you can use a pair of needle-nosed pliers to make neat, precise bends, a pair of diagonal cutters to snip the leads and wires to length, and a wire stripper to remove the insulation from the newly cut wire ends. Neatness can improve your clarity of understanding of the circuit. However, you will be graded on the function of your circuits, not their appearance.

Your breadboard has rows of connected holes that run the length of the breadboard, often with red and blue stripes marking them. They are usually used for the positive and negative terminals of the battery or other power supply voltage. Other components are inserted in the shorter 5-hole rows that run across the board. Figure P2-5 shows a typical component layout for a voltage divider.

Important! Disconnect the battery when you are not using the circuit (taking measurements). This is good advice for all of the labs. If you leave the battery connected when you are not using the circuit, the battery will discharge and you will have to buy another one.

Procedure 3 (20 points) Voltage Divider

In this procedure, you will build a voltage divider and compare the measured voltage to the ideal computed value.

a. (4 points) Draw a circuit diagram for a voltage divider using a 9 V battery, a 10 k Ω resistor, and a 30 k Ω resistor. For the benefit of the grader, connect one end of the 30 k Ω resistor to the negative battery terminal.

b. (4 points) Compute the value of the voltage across the 30 k Ω resistor in the circuit of part a using nominal component values (9 V, 10 k Ω , 30 k Ω). Also compute the range of voltage using a 5% resistor value tolerance.

c. (4 points) Measure and record the actual battery voltage and resistor values.

d. (4 points) Compute the value of the voltage across the 30 k Ω resistor in the circuit of part a using the measured component values from part c. Note whether this number is within the range computed in part b.

e. (4 points) Build the circuit in part a using the components you measured, and measure the actual voltage across the 30 k Ω resistor. Discuss any differences with the result from part d.

Procedure 4 (25 points) Current Divider

In this procedure, you will build a current divider and compare the measured voltage to the ideal computed value. (As an experiment, this is less satisfactory than the voltage divider because a battery is a voltage source, not a current source.)

- a. (4 points)** Draw a circuit diagram for a current divider using a 9 V battery, a 1 k Ω resistor, and a 300 Ω resistor. For the benefit of the grader, draw the 300 Ω resistor on the right side of the circuit.
- b. (4 points)** Compute the value of the current through each resistor, and the total current leaving the battery, in the circuit of part a. using nominal component values (9 V, 1 k Ω , 300 Ω). Also compute the range of total current using a 5% resistor value tolerance.
- c. (4 points)** Measure and record the actual battery voltage and resistor values.
- d. (4 points)** Compute the value of the current through each resistor and the total current leaving the battery in the circuit of part a using the measured component values from part c. Note whether the total current number is within the range computed in part b.
- e. (4 points)** Build the circuit in part a using the components you measured, and measure the actual current through each resistor, and the total current leaving the battery. Discuss any differences with the result from part c.
- f. (5 points)** Compute the power dissipated in each resistor. Do you expect either resistor to be hot? Check by touch - careful, don't get burned.

Procedure 5 (30 points) Voltage Divider Design

Figure P5-1 shows a transistor amplifier circuit, the basis for any number of electronic products like cell phones, radios and stereos. An important part of designing this circuit is biasing the transistor, meaning to set the steady state DC voltage of the transistor base, v_b . This is done with a voltage divider consisting of resistors R_1 and R_2 .

At first glance, R_1 and R_2 are not in a voltage divider configuration. There are two additional connections to node b , which connects the resistors. However, by using some knowledge about the circuit and the conditions of interest, both of these connections will prove to be approximately open circuits.

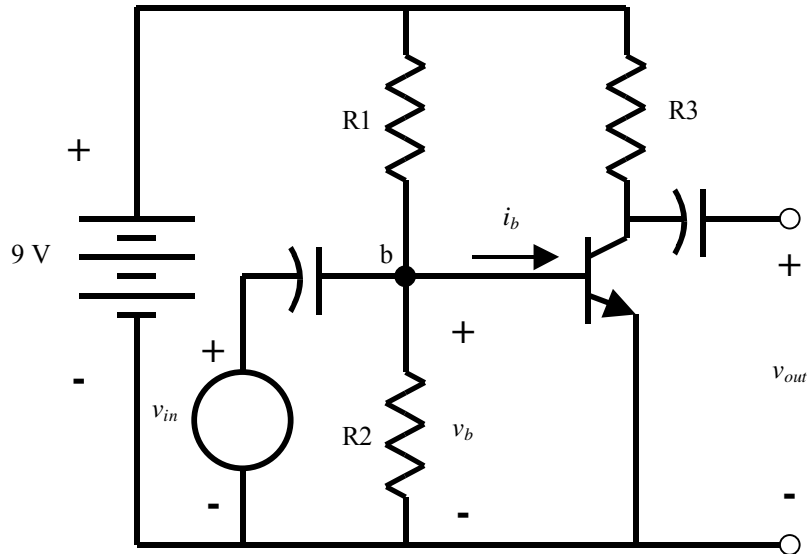

Figure P5-1 Common emitter transistor amplifier.

The first connection is a capacitor between node b and the input v_{in} . In steady state DC, capacitors are open circuits (see procedure O1 in this lab, for example). So for purposes of biasing the transistor, the connection to v_{in} is an open circuit.

The second connection is the transistor base. When you learn about transistors, you will discover that the base current, i_b , is "small". When someone says "small" like that, what is really meant is i_b is approximately zero. Zero current is an open circuit.

So you see that both of the extra connections can be treated as open circuits when computing the bias voltage, and R_1 and R_2 are a voltage divider for this purpose. This is a good example of how the ideal configurations we study in basic circuit theory are "hidden" in real circuits, and how knowledge of the component behavior can be used to make approximations that reduce the real circuit to a simpler one. A large part of engineering knowledge is learning when approximations are valid, and when they are not.

a. (20 points) Design a voltage divider using the set of resistors supplied with the lab kit to obtain a value of $v_b = 4.85$ V. Get as close to this value as you can. Ensure that the current through the voltage divider is greater than 0.1 mA (this keeps the " i_b is small" approximation true). Ensure that no resistor is overloaded (dissipates power greater than its power rating). Record your design (draw circuit and label values) and voltage and power calculations.

b. (5 points) Implement your design (just the voltage divider part!) on your breadboard. Measure and record the bias voltage you obtained. Show this to your TA, including measuring the desired voltage.

c. (5 points) Implement the voltage divider with a 10K Ω potentiometer. Adjust the potentiometer to get the voltage v_b as close as possible to 4.85 V. Sketch the circuit and record the value of v_b you achieved. Why would you not routinely use a potentiometer for this purpose? (Hint: Check the prices for resistors and potentiometers on the EE Stores web page. What else costs money in this step?)

NOTE: If you do not show your TA your circuit from part b, your grade for this procedure is zero.